

Sistema di travaso gasolio ad uso privato, consente un rifornimento degli automezzi pulito e veloce. Sono disponibili tutti gli accessori necessari al completamento del distributore.

Serie "Compact" composta da:



Art. 091-5081-045 Pompa 12V - cavo di alimentazione (sec. 4 mmq, 4 m) con pinze e fusibile - 45 l/min

Art. 091-5083-045 Pompa 24V - cavo di alimentazione (sec. 4 mmq, 4 m) con pinze e fusibile - 45 l/min



Art. 091-5081-060 Pompa 12V - cavo di alimentazione (sec. 4 mmq, 4 m) con pinze e fusibile - 60 l/min

Art. 091-5083-060 Pompa 24V - cavo di alimentazione (sec. 4 mmq, 4 m) con pinze e fusibile - 60 l/min



Art. 091-6100-060 Pompa elettrica AC 230V 50Hz MEC-60 l/min

Art. 091-6100-070 Pompa elettrica AC 230V 50Hz MEC-70 l/min

Art. 091-6100-100 Pompa elettrica AC 230V 50Hz MEC-100 l/min



Art. 091-6102-070 Pompa elettrica AC 115V 60Hz MEC-70 l/min

Art. 091-6102-100 Pompa elettrica AC 115V 60Hz MEC-100 l/min



Art. 908-0516-040 Tubo di collegamento Ø 20 mm M-M 1" lunghezza 4 m

Art. 908-0616-040 Tubo di collegamento Ø 25 mm M-M 1" lunghezza 4 m



Art. 093-5200-000 Pistola manuale in alluminio MC80 portata 80 l/min



Art. 093-5210-000 Pistola automatica PA60 portata 70 l/min

Art. 093-5220-000 Pistola automatica PA120 portata 120 l/min

OPTIONAL:



Kit tubo di aspirazione

Filtri a cartuccia

DISTRIBUTORI A PARETE PER TRAVASO GASOLIO "Compact"

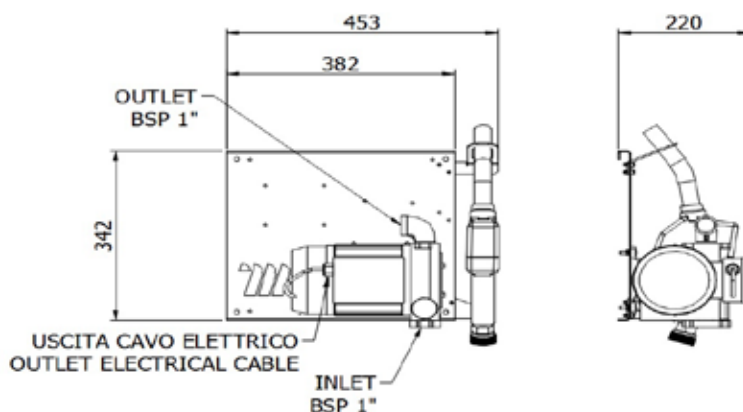

Codice	Descrizione	Portata	Tensione	Potenza	Entrata Uscita	Tubo colleg.	Pistola	Ciclo di lavoro	Peso	Imballo
		l/min	AC V./Hz DC Volt	W	BSPG	∅		min	Kg	mm

090-5043-060	Compact	60	230/50	440	F1" - F1"	20	Aut.PA60	Continuo	15,50	410X400X320
090-5043-070	Compact	70	230/50	480	F1" - F1"	20	Aut.PA60	Continuo	15,50	410X400X320
090-5043-100	Compact	100	230/50	800	F1" - F1"	25	Aut.PA120	Continuo	22,00	410X400X320
090-5044-060	Compact	60	230/50	440	F1" - F1"	20	Manuale	Continuo	14,90	410X400X320
090-5044-070	Compact	70	230/50	480	F1" - F1"	20	Manuale	Continuo	14,90	410X400X320
090-5044-100	Compact	100	230/50	800	F1" - F1"	25	Manuale	Continuo	21,00	410X400X320
090-5043-07X	Compact	70	115/60	650	F1" - F1"	20	Aut.PA60	Continuo	15,80	410X400X320
090-5043-10X	Compact	100	115/60	1045	F1" - F1"	25	Aut.PA120	Continuo	22,28	410X400X320
090-5044-07X	Compact	70	115/60	650	F1" - F1"	20	Manuale	Continuo	15,40	410X400X320
090-5044-10X	Compact	100	115/60	1045	F1" - F1"	25	Manuale	Continuo	21,30	410X400X320
090-5043-Y45	Compact	45	12	264	F1" - F1"	20	Aut.PA60	40	12,15	410X400X320
090-5043-Z45	Compact	45	24	312	F1" - F1"	20	Aut.PA60	40	12,15	410X400X320
090-5043-Y60	Compact	60	12	336	F1" - F1"	20	Aut.PA60	40	13,30	410X400X320
090-5043-Z60	Compact	60	24	432	F1" - F1"	20	Aut.PA60	40	13,30	410X400X320
090-5044-Y45	Compact	45	12	264	F1" - F1"	20	Manuale	40	11,60	410X400X320
090-5044-Z45	Compact	45	24	312	F1" - F1"	20	Manuale	40	11,60	410X400X320
090-5044-Y60	Compact	60	12	336	F1" - F1"	20	Manuale	40	12,75	410X400X320
090-5044-Z60	Compact	60	24	432	F1" - F1"	20	Manuale	40	12,75	410X400X320